

TRUE 3D VISUALISATION OF MOUNTAINOUS TERRAIN BY MEANS OF LENTICULAR FOIL TECHNOLOGY

Manfred BUCHROITHNER, Klaus HABERMANN & Thomas GRÜNDEMANN

Dresden University of Technology

Institute for Cartography

manfred.buchroithner@mailbox.tu-dresden.de

ABSTRACT

Following the conceptual idea "from 3D sensor and data to 3D view", the production of a prototypic true-3D image map of the Granatspitz Massif in the Eastern Alps, near Austria's highest peak, Grossglockner (3794 m), is described. Since the mountains around the Alpine Centre Rudolfshuette in the Austrian Alps represent an internationally renowned skiing, hiking, rock- and ice-climbing site, the envisaged map should and by now is able to respond to an existing tourism demand. A true-colour image-line map in true 3D appears to cover the requirements of out-door sportsmen best.

The paper gives an overview about the basics and the different methods to generate 3D visualisations, followed by a description of the 3D data generation based on the High Resolution Stereo Camera (HRSC) developed by the German Aerospace Centre (Deutsches Zentrum für Luft- und Raumfahrt, DLR). The excellent radiometric properties of the imagery proved ideal for a true-colour depiction of this high-relief terrain containing both clear water bodies and snow-covered glaciated peaks reaching above 3000 m.

In order to be able to view the map without viewing aids like polarisation glasses the decision was made to generate it on the basis of lenticular lenses. These micro-lenses on the surface of a transparent plastic foil allow the map user to view the integral of two or more interlaced strips of stereo-mates through this foil with the left and right eye respectively. This method provides the possibility of a spontaneous true-3D visualisation. The calculation of both the strip width and the interlacing is done by means of commercially available software for image processing, remote sensing, CAD, DTP and 3D modelling.

Due to the interlacing of the sub-millimeter strips of the stereo-mates and the resulting decomposition in x direction, the integration of well-designed and easily legible signatures and letterings represent a challenge. The paper describes the lenticular lens principle, the image map generation and, in particular, the actual cartographic work with different approaches for both signatures and lettering.

The spontaneous recognition of the relief makes the use of elevation contours and spot heights not dispensable. It is, however, necessary to adjust this information. The contour interval has for example to be chosen bigger than in a conventional map. Furthermore, it proved beneficial to brighten the natural shadow areas for the prevention of relief reversion effects.

Important steps in the production process were the registration of the map data to the geometry of the lenticular foil and the fine-tuning of print resolution, image depth and number of stereo-mates. The image data received by the HRSC determined the size of the map field (42 cm * 54 cm), of the whole map format (60 cm * 80 cm) and the scale (1:17 500).

Future research will be concentrate on signaturation and lettering.

1 BACKGROUND AND MOTIVATION

Based on unpublished studies of Manfred F. Buchroithner more than 60 percent of all map users are not in the position to spontaneously derive information about the third dimension from conventional topographic maps (even with hill-shading). This applies especially to high-relief terrain. The studies were carried out in the

1970ies and 1980ies, the probationers were members of high-alpine hiking courses. The findings of these tests triggered today's efforts to enable the map user - or better the map reader – to spontaneously perceive the relief information with unaided eyes, i.e. without the use of either anaglyph glasses, polarisation glasses or chromadepth glasses.

In a first step a high-mountain map based on the principle of a whitelight-transmission-hologramme (holostereogramme) was produced (Buchroithner & Schenkel, 1999, Buchroithner, 2000, Kirschenbauer & Buchroithner, 1999). Until present the necessity of illumination with coherent light and the high production costs prevent the successful practical implementation of high-quality holographic maps.

Therefore, other possibilities for true-3D hardcopies were searched, following the idea of better acceptance by the map readers and – primarily – significant lower production costs. Some years ago the first promising tests with lenticular foils took place at the Institute for Cartography of the Dresden University of Technology. The positive echo caused by these first test-pieces made the authors optimistic for the production of large-format high-mountain maps.

2 BASICS OF LENTICULAR METHOD

2.1 Principle

The lenticular method uses a transparent synthetic foil for the stereo-image separation. On its upper side there are semi-cylindrical parallel micro-lenses running in vertical direction. The bottom side is plain and represents simultaneously the image plane. The lenses focus incoming optical rays at the image plane, which means that focal and image plane are identical.

Following Okoshi (1976) "the word 'lenticular' is originally an adjectival form of lens. It is merely a matter of custom that we use this word only for the cylindrical lens sheet, but not for fly's-eye lens sheet." Consequently, the exclusive use of this term is nowadays generally accepted as the correct name for this technique.

Under the lenses interlaced lamellar "subimages" are arranged. The lenticular image will be generated in a way that under every lense one pixel column of all stereo-mates is arranged (cf. Figure 2).

The interlaced "subimages" are projected in different directions, based on the optical properties of the lenses. Consequently, the left and the right eye perceive different stereo-mates. This explains why it is possible to extract spatially separated image information from only one hardcopy.

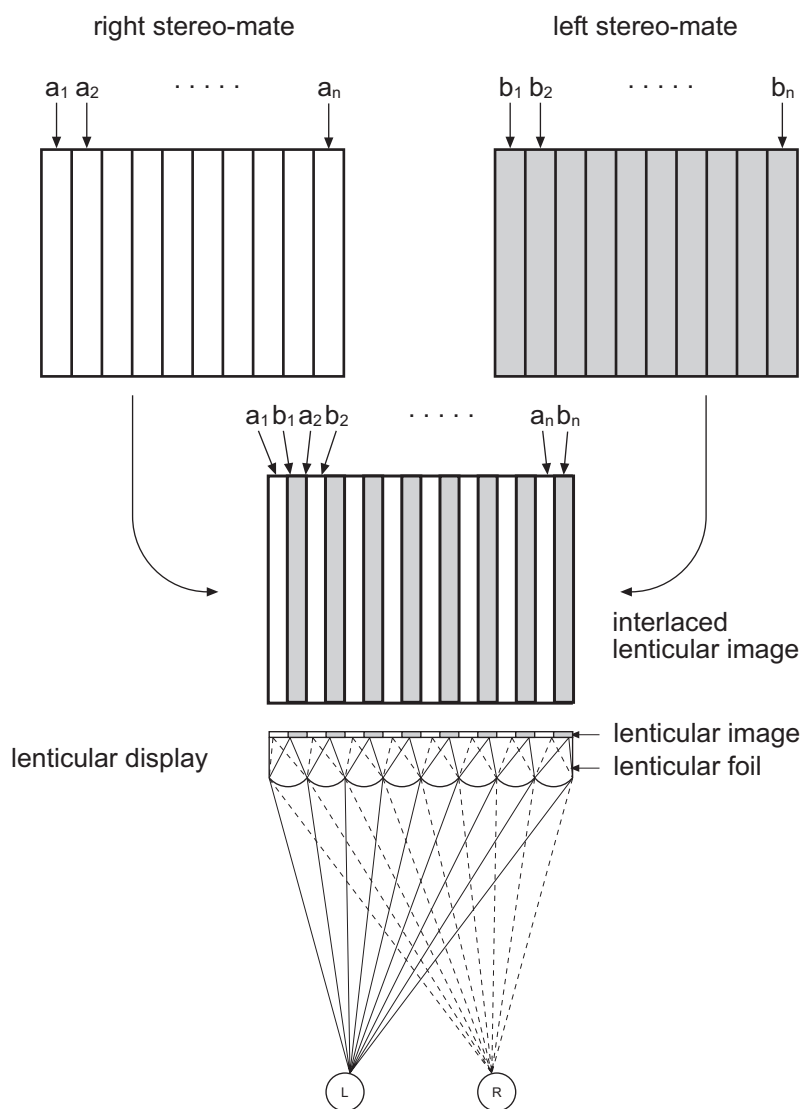

Figure 1: Interlacing of "subimages" and principle of 3D-lenticular method.

For the consideration of the individual eye distances and for a smoothly "sliding" viewing angle it is advisable to increase the number of subimages, i.e. stereo-mates, from two to five and more. Thus, the observer obtains a certain degree of freedom for side-movements and laterally oblique views. The increase of the corresponding possible parallaxes allows the perception of more perspectives, and the lenticular image can be perceived from different directions. So a "moving parallax" and the multi-user capability is realised (Bahr, 1991). As long as one stereoscopic image pair is perceivable, a true 3D impression is perceivable.

2.2 Characteristics of Lenticular Foils

Shape and size of the lenses determine the characteristics of a lenticular foil. The important parameters are:

- lens density (number of lenses per unit length) or lens width w
- radius r
- thickness of lenticular foil t
- aperture angle of the lenses ϕ
- refractive index n .

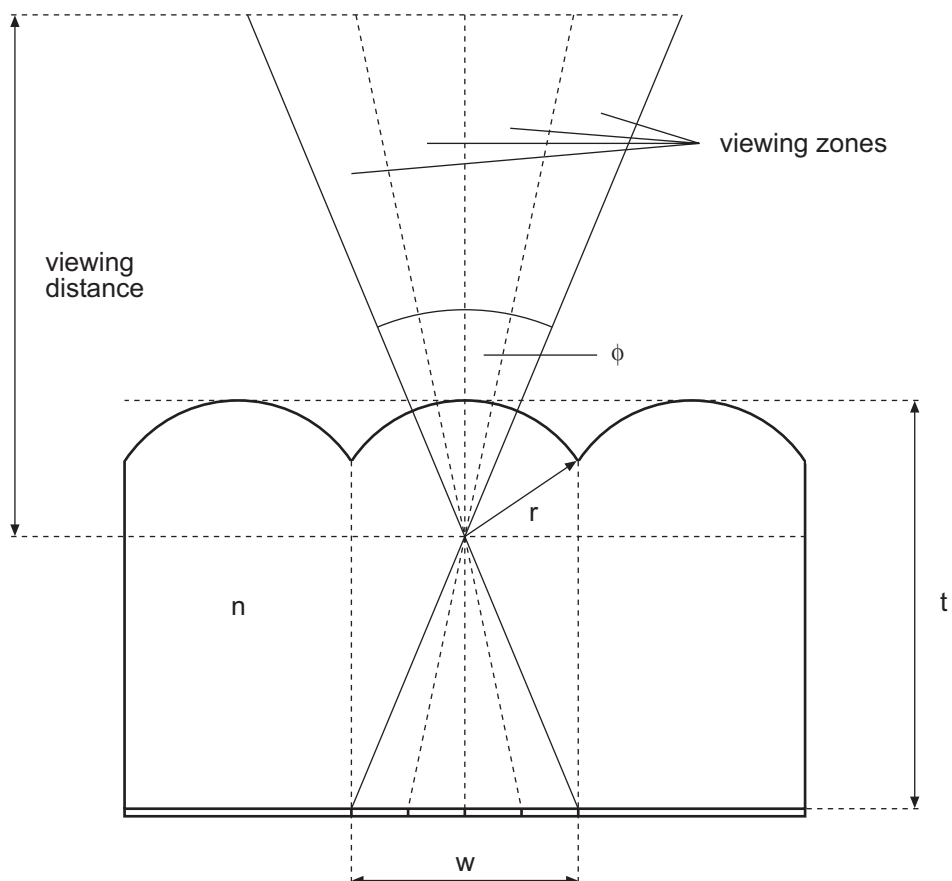

Figure 2: Parameters of the lenticular foil.

One of the most important parameters of a lenticular foil is the lens density: common is the declaration in lenses per inch. The choice of the lens density determines factors like:

- size of the perceived pixels (resolution of the lenticular image)
- number and width of the subimages/laces under a lens, and
- viewing distance.

Indeed, these factors are not accordable without compromises. A particular pixel will only be perceived within the width of one lens and has thus direct influence on the richness of detail of the whole lenticular image. However, with rising lens density decreases the printable area per lens. Hence, either the number of "subimages" has to be reduced - which is followed by the occurrence of leaps between adjacent "subimages" - or the width of the discrete "subimage" strip has to be reduced which causes very high requirements concerning print resolution and registering accuracy. The maximum number of subimages depends directly on the quality of the lenticular foil. Lens defects provoke that the incoming rays cannot focus in the focal plane.

Often the thickness of the lenticular foils is specified. Thickness, radius and refractive index of a lense are highly correlated, because – as already mentioned – focal and image plane must be identic in order to produce high-quality lenticular images. A changing of the radius results in a shift of the focal plane. Consequentially, thicker lenticular foils have bigger lens radii and a smaller viewing angle. They are best for lenticular images with 3D-effects.

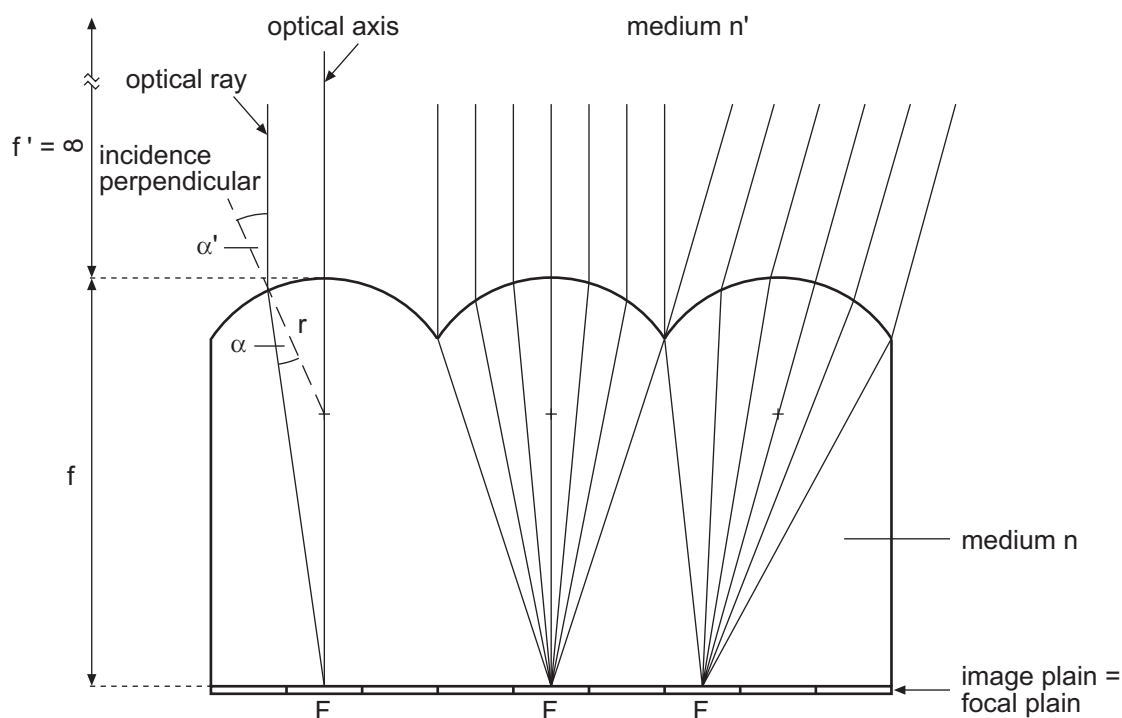

Figure 3: Optical paths in the lenses.

The aperture angle of a lens is defined by the projection plain of all "subimages" in the space above the lens. This angle can be subdivided into discrete so-called viewing zones corresponding to the "subimages". Outside the aperture angle occurs a repetition of the depicted objects. The aperture angle is determined by the radius of the half-cylindrical lenses and the refraction characteristics of the material.

All the above parameters have to be chosen in a way that the foil is optimal for the intended purpose. In order to reach a good 3D impression a small aperture angle is advantageous, normally approx. 30 degrees. This value also follows from the intention to create small viewing zones for the discrete "subimages" based on a small aperture angle. This, again, reduces the risk of the synchronous viewing of the same "subimage" with both eyes. Thus, a 3D impression is already reached at a viewing distance of only 15 cm and will remain at significantly longer distances.

A large horizontal parallax causes disturbing side-effects when changing the viewing angle, i.e. the "leaping" of the 3D scene. This effect is due to the finite number of subimages. It is possible to minimise it through an increased number of "subimages", i.e. through the shortening of the horizontal parallaxes and, hence, the reduction of the depth impression.

Besides the 3D visualisation lenticular foils are also useful for other purposes. When using horizontal lenses both eyes get the same image information. This is useful for the perception of animations (changes, morphings) or of different images (flips) through the tilting of the lenticular image. To a limited degree these effects are also realisable by vertical runs of the lenses, so that combinations of 3D-images with different contents are possible (cf. title page of this issue).

A more comprehensive presentation of all the above aspects is given in a monograph by Th. Gruendemann (2004).

2.3 Preparation of Lenticular Images

The data sets used for the described product were delivered in digital form, and this determined the subsequent production process. The software package used for the calculation of the "subimages", of the stereo-mates, has to provide capabilities for the processing of DTMs and large image data sets. Additionally, it must be possible to define the parameters of inner and outer orientation of a virtual camera.

Once the 3D model itself is well-defined in all respects, there exist two basic ways to position the camera in a sequence of viewpoints:

- convergent camera (convergent disposition)
- parallel camera (parallel disposition).

When using the method of the convergent camera, all camera axes intersect in one point, resulting in a symmetric viewing pyramid for all stereo-mates. A disadvantage of this method represent the vertical parallaxes close to the image edges: the objects will be depicted with heavy distortions.

The typical characteristics of the other method are parallel camera axes. Here, the viewpoints will be moved along a straight path. For the coverage of the same model subset the use of asymmetric viewing pyramids is recommendable (cf. 5). They avoid a subsequent peripheral cutting of the stereo-mates.

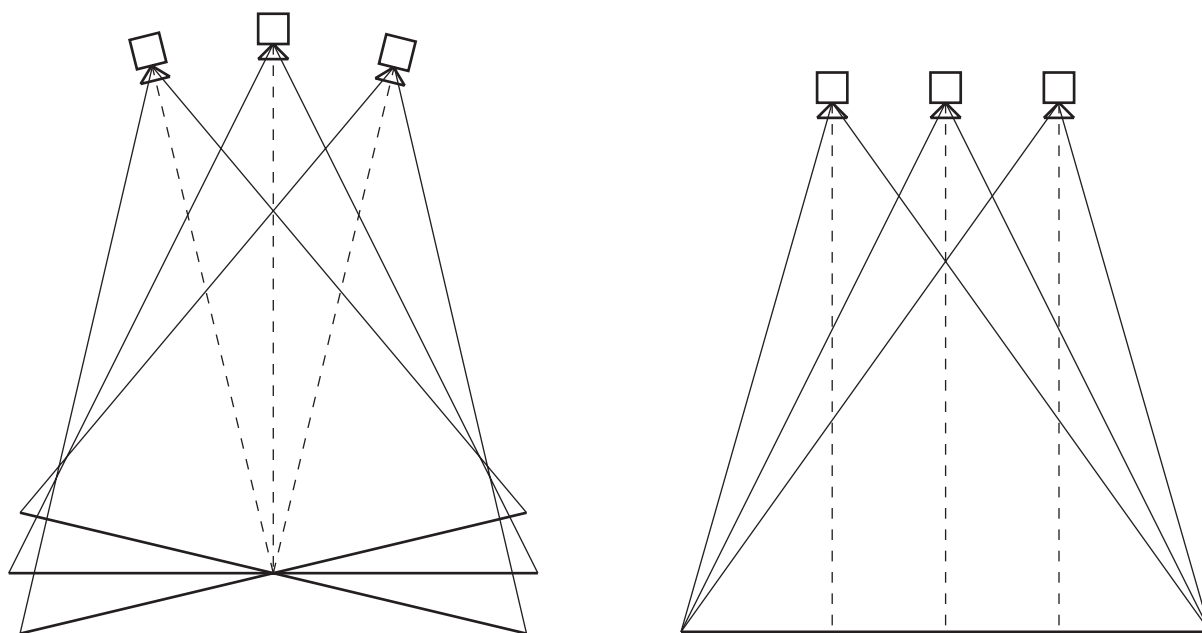

Figure 4: Convergent and parallel camera positioning.

3 DATA SOURCES AND OBJECTIVES

The production of a first prototype of a true-3D map based on lenticular foil technology was one activity within the Mars Express (MEX) Mission by ESA/DLR running since December 2003. The High Resolution Stereo Camera (HRSC) onboard the Mars Express spaceprobe developed by the Institute of Planetary Research of the German Aerospace Centre (Deutsches Zentrum für Luft- und Raumfahrt, DLR) is a multi-line scanner with several scan angles and wavelengths. The data processing delivers synchronously ortho-image data sets in blue, green, red, and near infrared as well as a DTM (Hauber et. al., 2000). The applicability of the HRSC data for these tests is based on the good fitting between image data and DTM inherent to the system.

In preparation of MEX some airborne missions with the HRSC took place. Objects of early tests were the volcanic island of Stromboli, and the area around the internationally well-known "Alpin-Zentrum Rudolfshütte" in the Eastern Alps (Hauber et. al., 2000). On September 14, 1999 an area of approx. 90 km² (7.7 km W-E and 11.5 km N-S) was covered by 21 flight strips taken by a one-to-one-model of the Mars camera.

The original data, received with a ground resolution in the decimeter range, were resampled to a resolution of 1 m. For the described data take the near-infrared band was not processed. The derived DTM has a horizontal resolution of 1 m, the vertical resolution being 0.1 m.

For the insertion of map information the 1:25 000 Alpine Club Map "Granatspitzgruppe" (Alpenverein, 2002) was analysed. Trails, water bodies, boundaries, letterings and spot heights were digitised and stored in a well-structured way. In a second step it was necessary to accurately drape the image data. In contrast to the available

DTM, the registration of the spot heights serves the linkup of the extrema of the initially unlabelled relief with the lettering.

The decision to register the map data to the image data, was made after terrain inspection by Bernhard Zigel, University of Salzburg, with a hand-held GPS receiver. Subsequently, a significantly better fitting of the image data to the digital terrain in comparison to the initial (locally slightly distorted) map (Zigel, 2003) could be reached. This procedure seemed to be most appropriate and effective.

The processing of the 3Dmodel with the software package 3D Studio MAX requires the conversion of the raster DTM into a grid model. For this purpose an interface was created which delivers polygon meshes in the DXF format.

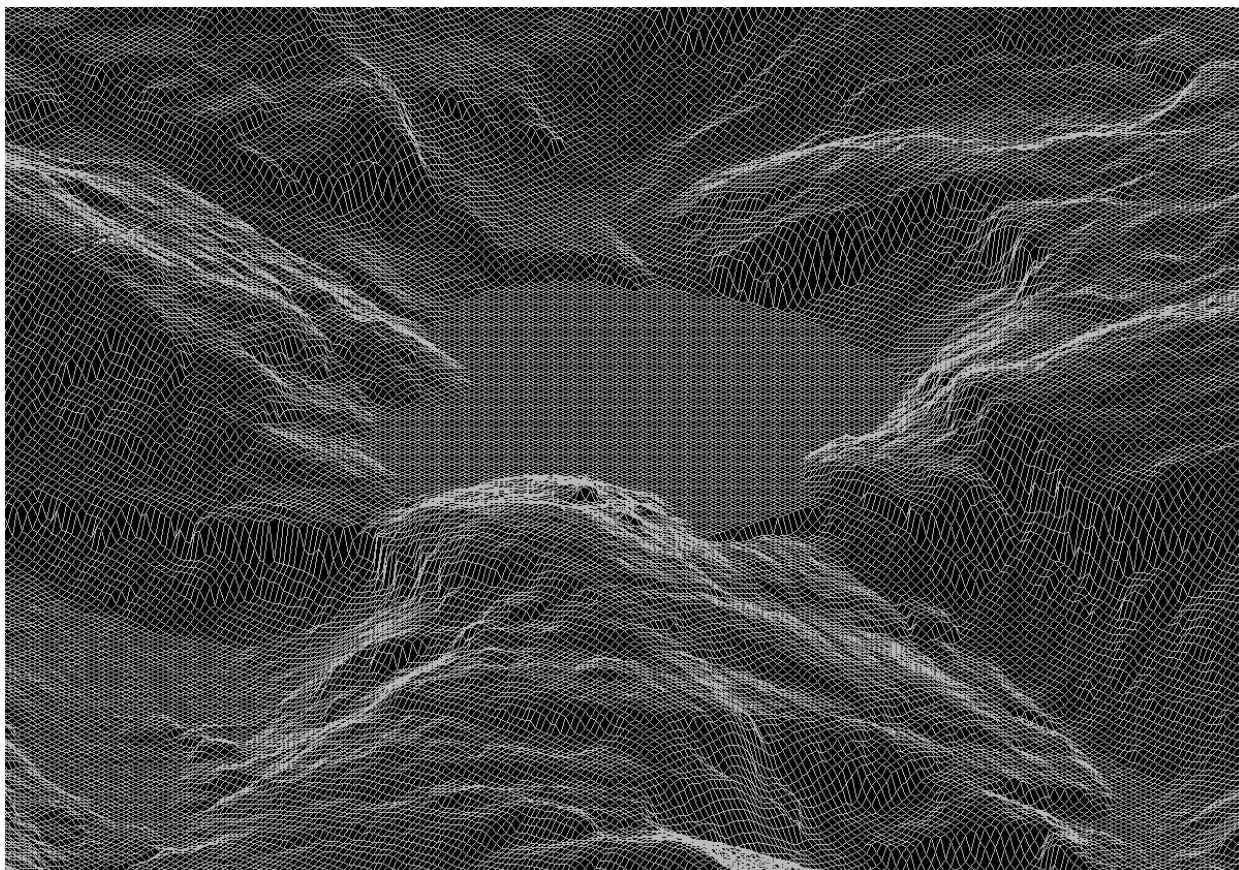

Figure 5: Grid DTM, view of Weisssee from north-east. For the visualisation grid-width decreased to 10 m.

Due to the fact that the mountain region around the Alpin-Zentrum Rudolfshuette is an internationally renowned skiing, hiking, rock- and ice-climbing area, the described map should cope with the tourism requirements. A true-colour image map in true-3D could doubtlessly perform this task best. As already mentioned, the usage of lenticular foils avoids the use of eye aids like polarisation glasses or the like.

True-3D displays in digital and analogue form require interfaces to operational modelling software and output devices. For high-quality hardcopies algorithms and methods have to be developed and tested which allow the operational production of high-resolution true-3D displays based on lenticular foil technology.

Due to the fact that excellent image data were available, the decision for the production of a combined image-line map (CIL) was made very early. Such a map combines the advantages of a foto-realistic display with the communication properties of abstracted, symbolised cartographic information (Buchroithner & Kostka, 1997).

4 TREATMENT OF IMAGE AND MAP INFORMATION

One indisputable requirement for the production of a homogenous high-quality image map is the brightening of the shadow areas. Since during the mosaicing process at DLR almost all pixels got synthetically calculated grey values assigned, the calculation of a shadow mask based on the reconstruction of the illumination conditions during the 3-hour datatake was hardly possible. Instead, a classification of the shadow areas was made. Based on this mask the respective areas were then brightened. Consequently, the features in the shadow areas became better visible, the remaining shadows act as a kind of analytical hill-shading.

Although the generated image map is a product which allows spontaneous relief recognition, the insertion of absolute altitude values was desirable. This also allows the map user to estimate the slope gradients, also in the case of exaggeration factors unequal 1. After tests with contour intervals of 100, 200, 500 and 1000 m the 200 m interval was found to be a good compromise between a too high density of elevation contours and a too low coverage of the image data by these vectors. The contour lines were reinterpolated from the DTM, followed by a smoothing step. Furthermore, peak and saddle elevations were indicated by spot heights. The elevation counts were positioned manually.

Relief and vector data were inserted into the 3D-model in different steps. This separation was not determined by the contents but rather by the attempt to prevent unwanted artefacts like the contour vectors undercutting the relief, when it has a convex form between two vertices. This would consequently result in a spot where the contour line is invisible.

The minimum size of the lettering is determined by the lenticular foil used. In the present case it was 12 point. So it was necessary to integrate only a selection of geographic names and unnamed spot heights. Hence, the lenticular map does not represent the whole content of the Alpine Club Map. A summary of all the described aspects is given in the following table:

Table 1: Inserting vector information into the 3D-model.

Placement of vector information in relation to the relief			
Identical with relief	Identical with relief - merged with image data	Nearly identical with the relief - manual placement	Significantly hovering above the relief
Image data	Elevation contours, boundaries, road network, water bodies	Signatures, elevation figures	Geographic names, lettering in general

One big advantage of a true-3D map based on lenticular foil technology is the possibility to layout the whole vector information, primarily the symbols and the lettering, in a way that they do not hide the surface, i.e. in this case the relief and image information. These map elements can be placed in a way that they seem to be hovering above the terrain. This effect also allows the correct representation of the cables of cable cars at their actual three-dimensional position.

In contrast to conventional parallax stereoscopy, for a high-quality true-3D representation there are significantly more than two stereo-mates necessary. In a kind of synthetic west-east overfly 20 parallel perspective views were generated with a "virtual" camera. This delivers a smooth transition when changing viewing angle along the x-parallax (cf. above).

The calculation of the discrete 3D views has been carried out by the software packages SCOP++ and SCOP classic (Vienna Univ. of Technology) and for the vector data and the lettering with 3D Studio MAX. The interlacing of the stereo-mates was a task for the commercial software MAGIC INTERLACER Pro 100, a plug-in to Adobe Photoshop. For the cartographic works the DTP package MACROMEDIA Freehand was used.

5 MAP LAYOUT

In an effort to obtain an optimal tuning between the presented area, the spatial resolution of the image data and the parameters of the lenticular foil in connection with a "round" scale, the map area resulted in a format of 42 cm (West - East) and 54 cm (North - South) at scale of 1 : 17 500.

Out of three possible layouts – one portrait and two landscape formats – the choice was a landscape format with the map area on the left side, covering slightly more than half the print format of 60 cm * 80 cm, and title, index map, legend, scale, geodetical basics and imprint at the right side above each other.

The final layout of the map with a bilingual title in English and German "GRANATSPITZ MASSIF, Hohe Tauern Range, Austria/Granatspitzgruppe Hohe Tauern, Österreich" is given in Figure 7 (cf. Buchroithner et al., 2003).

Map elements which are not represented in true-3D, i.e. outside of the map field, are also printed on the lenticular foil. Hence, it was here, too, necessary to use the minimal letter sizes of 12 point.

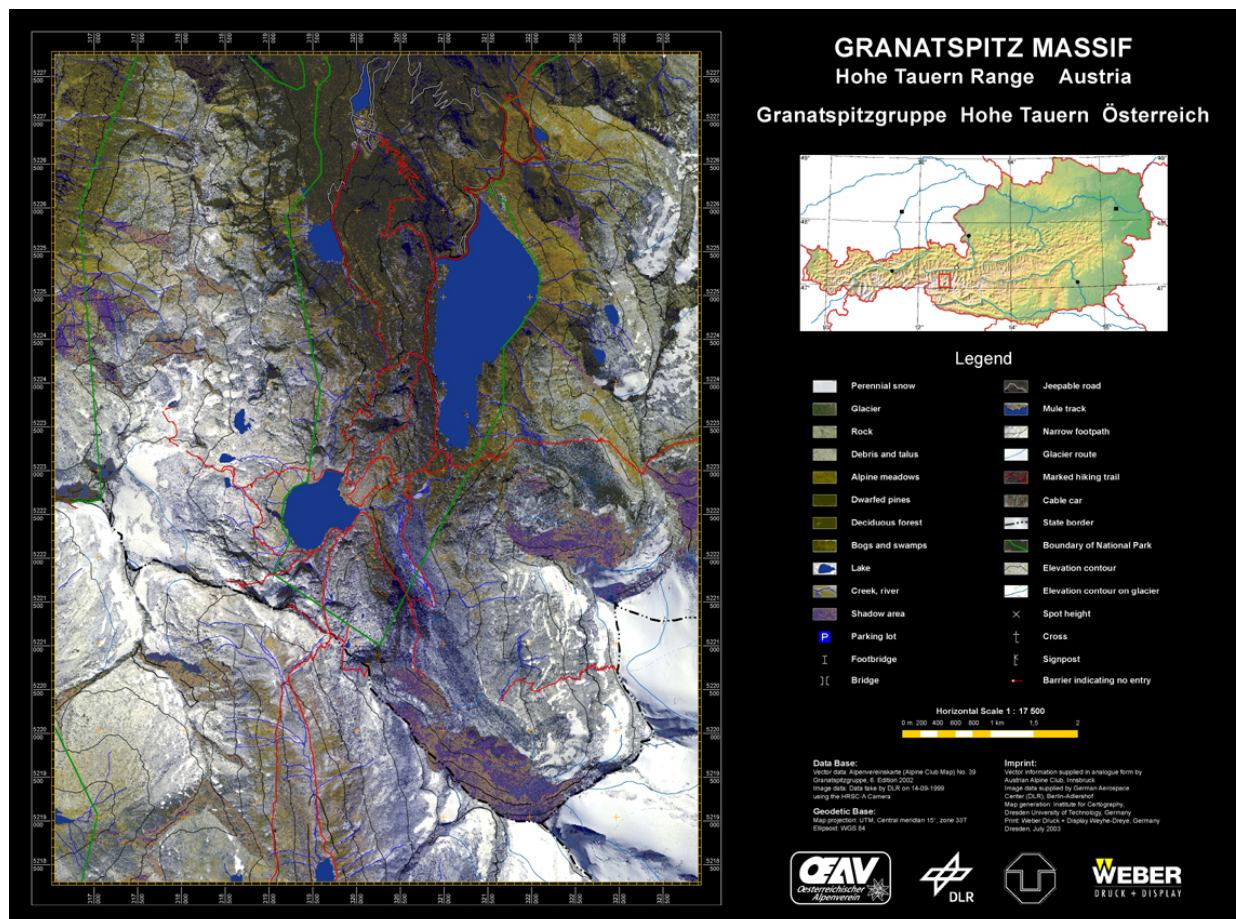

Figure 7: Layout of the lenticular map.

6 EVALUATION

At the Institute for Cartography of the Dresden University of Technology the first high-mountain map worldwide which is auto-stereoscopically viewable with unaided eyes was produced. In comparison to other true-3D visualisation techniques for digital displays the big advantages of this hardcopy are easy transportability and multi-user capability. This allows to take the map into the terrain, both as a whole or in parts, mounted on a flexible tissue. The biggest advantage, however, is that neither a special illumination, like for a hologramme, nor glasses are necessary. The combination of a hill-shading – synthetic or natural – and partly hovering topographic line information represents an optimised information transfer for the map user. In summary, it has to be stated that this innovation in cartographic visualisation to present the third dimension yields enormous benefits for all individuals who have difficulties to spontaneously extract relief information from conventional maps. This offers a high potential for future applications in both topographic and thematic cartography.

Presently, photogrammetric data processing and cartographic work is mostly carried out digitally. Yet, for lenticular maps this view is rather optimistic. For the production of high-quality graphics in the form of high-

resolution 3D hardcopies still many visual checkups are necessary. In any case, the operational visualisation of digital 3D models in the form of user-friendly true-3D maps will be possible in the medium future.

ACKNOWLEDGEMENTS

Much of the basic research for the use of the lenticular foil technology for true-3D visualisation has been triggered by Prof. Gerhard Neukum, Free University of Berlin, Principal Investigator of the HRSC Experiment on the ESA Mars Express Mission. The funding of the R & D activities carried out within the scope of this project came from the German Ministry for Education and Research via the German Aerospace Center (DLR). Printing of the described map has, in the usual, experienced and excellent way, been carried out by Weber Druck + Display, Weyhe-Dreye near Bremen. Thanks go to all these individuals and institutions.

REFERENCES AND BACKGROUND READING

Albertz, Jörg (1997): Die dritte Dimension – Elemente der räumlichen Wahrnehmung. In: Albertz, Jörg (ed.): Wahrnehmung und Wirklichkeit – Wie wir unsere Umwelt erkennen und gestalten. Schriftenreihe der Freien Akademie Berlin, Vol 17., Berlin.

Bahr, Achim (1991): Stereoskopie - Räume - Bilder - Bildräume, Thales Themenheft Nr. 49. Thales Verlag, Essen, 47 p.

Buchroithner, Manfred F. (2000): Erste Holographische Hochgebirgskarte. Salzburger Geograph. Arbeiten, Vol. 36, p. 39-47.

Buchroithner, Manfred F., Kostka, Robert (1997): Conceptual Consideration on High-Mountain Cartography and Spaceborne Remote Sensing. In: Proc. 18th ICA/ACI International Cartographic Conference, Stockholm, Vol. 4, p. 2056-2059.

Buchroithner, Manfred F., Schenkel, Robert (1999): 3D Mapping with Holography. In: GIM International, 13 /8, p. 32-35.

Buchroithner, Manfred F., Wälder, Olga, Habermann, Klaus, König, Björn (2003): Generating a True-3D Image Map of High Relief Terrain Using Lenticular Foil. Proc. 21st Internat. Cartographic Conf., Durban, p. 1323-1328.

Gründemann, Thomas (2004): Grundlagenuntersuchungen zur kartographischen Echt-3D-Visualisierung mittels des 3D-Lentikularverfahrens. Studienarbeit, TU Dresden, 45 p.

Hauber, Ernst, Jaumann, Ralf, Wewel, Franz, Gwinner, Klaus, Neukum, Gerhard, Slupetzky, Heinz (2000): The Airborne High Resolution Stereo Camera (HRSC-A) as a Tool for High Mountain Cartography, Kartographische Bausteine, Vol. 18, TU Dresden, p. 29-38.

Kirschenbauer, Sabine, Buchroithner, Manfred F. (1999): "Real" 3D Technologies for Relief Depiction. In: Proc. 19th ICA Intern. Cartogr. Congress, Ottawa/Canada, August 14-21, p. 1-7.

Kraus, Karl (1997): Photogrammetrie, Band 1 - Grundlagen und Standardverfahren. Ferd. Dümmler Verlag, Bonn, 394 p.

Österreichischer Alpenverein (2002): Alpenvereinskarte Granatspitzgruppe 1:25 000, Innsbruck.

Okoshi, Takanori (1976): Three-Dimensional Imaging Techniques, New York Academic Press, 403 p.

Zagel, Bernhard (2003): E-mail correspondence with Klaus Habermann.

Corresponding Author:

Manfred F. Buchroithner

Institute for Cartography
Dresden University of Technology
D-01062 Dresden, Germany

Tel.: +49 351/463-34809

Fax: +49 351/463-37028

E-mail: Manfred.Buxchroithner@mailbox.tu-dresden

Homepage: <http://web.tu-dresden.de/kartographie>